

TAKSTAR® 得胜



E188 **新版** 有线扩音器
Wired Amplifier

使用手册 User Manual

■ 前言

尊敬的用户：

感谢您选购得胜E188（新版）有线扩音器，为了您能够更好的了解使用本产品，建议您在使用前仔细阅读本说明书。

若存在有疑问或者您有宝贵的建议，可通过拨打得胜官方服务热线400 6828 333或微信扫描二维码关注得胜官方公众号与我们联系。



■ 产品特性

- 全新外观设计，造型新颖时尚，轻巧便携；
- 数字扩音技术，10W大功率音频输出，声音清晰保真；
- 无线播放功能，可连接手机、电脑、PAD等设备播放音乐；
- 具有音乐播放功能，支持U盘、TF卡的多媒体音频播放；
- 具有AUX音频信号输入功能，可充当小音箱使用；
- 内置2000mA可充电锂离子电池，节能环保，续航约15小时；
- 内置MCU智能充电管理系统，防过充保护，使用安全可靠；
- 壳体采用ABS工程原料成型，经久耐用；
- 具有肩挂及腰挂等多种佩戴方式，使用更方便。

■ 适用范围

- 适用于教学、导游、培训、促销等场合扩音

■ 产品配置

- E188扩音器.....1台
- 有线头戴麦克风 1个
- 肩带.....1条
- 充电线.....1条
- 说明书.....1份

■ 技术参数

主机（扩音器）参数

- 频率响应：80Hz-18KHz
- 额定功率：5W
- 峰值功率：10W
- 扬声器阻抗：4Ω
- 无线连接版本：5.0以上
- 电池类型：锂离子电池
- 电池规格：3.7V/2000mAh
- 工作电压：DC 3.5-4.2V
- 充电电压：DC 5V/1.5A
- 使用时间：约15小时
- 充电时间：约1.5小时
- 充电方式：Type-C
- 产品规格：100*90*35.5mm
- 产品重量：约200g

拾音器音头参数

- 拾音器：背极式驻极体
- 指向性：单指向
- 频率响应：100Hz-12.5KHz
- 灵敏度：-42~-48dB (0dB=1V/Pa, at 1KHz)

注：以上数据由得胜实验室测试得到，并拥有最终解释权！

■ 功能示意

扩音器

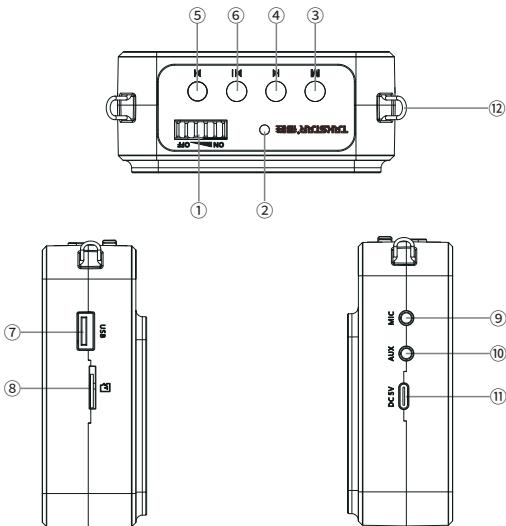

- ① 电源开关和音量调节旋钮：向“ON”方向拨动旋钮，听到“哒”一声，表示扩音器已通电并进入人声扩音状态，此时电源指示灯②亮蓝灯，继续向“ON”方向拨动声音逐渐增大；反之向“OFF”方向拨动则声音逐渐减少，直至听到“哒”一声关机。
- ② 电源指示灯：电量充足时，指示灯常亮蓝灯；当指示灯红灯闪烁时，表示扩音器处于低电量状态，请及时为扩音器充电；充电过程中，指示灯常亮红灯，充满后蓝灯常亮。
- ③ “M”模式切换键：开机状态下，短按该按键可切换工作模式，并伴有相应的语音提示。
- ④ ⏮ 上一曲按键：在蓝牙、U盘、TF卡播放状态下，短按此键为切换上一曲。
- ⑤ ⏭ 下一曲按键：在蓝牙、U盘、TF卡播放状态下，短按此键为切换下一曲。

⑥ **▶||** 播放/暂停按键：短按此按键控制音乐的播放及暂停；在蓝牙播放状态时，长按此键可以断开蓝牙连接。

⑦ U盘接口：可将储存有音频文件的U盘插入此孔进行播放。

⑧ TF卡接口：按照正确插卡方向插入TF内存卡。插入时，听到“哒”一声，表示已安装到位；取卡时把卡往下按压，听到“哒”一声，TF内存卡将自动弹出来。

提示：请确保TF卡中储存的是MP3、WAV格式的音频文件，否则不能正常读取歌曲文件甚至会有损坏机器的风险；拷入歌曲前请先将TF卡按FAT16、FAT32格式进行格式化，其他方式的格式化（如exFAT、NTFS格式）会导致录音无法保存或者储存的歌曲无法播放。

⑨ MIC输入接口：将有线麦克风插头插入此孔，进入有线人声扩音状态。操作时，请不要将麦克风的拾音面朝向扩音器的扬声器，以免产生啸叫。

⑩ AUX输入接口：通过Φ3.5mm音频连接线与手机、电脑、平板等播放设备连接，可将扩音器作为有源音箱使用。

⑪ 充电接口：连接Type-C充电线为扩音器充电。

⑫ 挂扣：用于安装肩带，可将扩音器斜挂于肩上使用。

■ 使用说明

一、使用方法

1. 将头戴麦克风正确佩戴于头部，并调整好麦克风的拾音角度；
2. 将有线头戴麦克风的Φ3.5mm插头插入扩音器的MIC输入接口内；
3. 打开扩音器电源开关，电源指示灯亮蓝灯，调整旋钮至合适音量；
4. 在使用过程中，若指示灯红灯闪烁时，表示扩音器电量不足，请及时充电。

提示：初次使用时，建议先充满电；如长时间不使用，需每半年给扩音器充一次电，避免电池过放，对电池性能产生影响。

二、蓝牙配对

首次使用本机时，需要与手机或蓝牙设备配对连接，步骤如下：

1. 先打开扩音器的电源开关，短按“M”键切换为蓝牙模式，此时指示灯蓝灯闪烁，表示蓝牙正在搜索配对状态。

2.进入手机“设置”菜单，找到蓝牙功能选项，开启手机蓝牙功能，待搜索到“TAKSTAR E188”，点击“TAKSTAR E188”进行连接，当扩音器语音提示“蓝牙已连接”，此时蓝灯恢复长亮，表示蓝牙连接成功；手机、电脑、平板等设备蓝牙连接扩音器成功后，即可实现音乐播放功能。

下次开机后点按“M”键开启蓝牙模式时，如果是已有连接过蓝牙，则自动回连最后一次使用的蓝牙设备，同时伴有提示音“蓝牙已连接”。

■ 安全警示

为避免电击、高温、着火、辐射、爆炸、机械危险以及使用不当等可能造成的人身伤害或财产损失，使用本产品前，请仔细阅读并遵守以下事项：

1. 使用产品时请确认所连设备与本产品是否匹配以及合理调整音量大小，不要在超过产品功率及大音量下长时间使用，以免造成产品异常；
2. 使用中若发现有异常（如冒烟、异味等），请立即关闭电源开关并拔掉电源插头，然后将产品送售后服务网点检修；
3. 消费者若使用电源适配器供电，则应购买配套使用获得CCC认证并满足标准要求的电源适配器；
4. 本产品及配件都应放置在室内干燥通风处，请勿长期存放在潮湿、灰尘多的环境，使用中避免靠近火源、雨淋、进水、过度碰撞、抛掷、振动本机及覆盖通风孔，以免损坏其功能；
5. 若产品需要固定于墙壁或天花板时，请确保固定到位，防止因固定强度不足导致产品发生跌落危险；
6. 使用该产品时需遵守相关安全规定，法律法规明确禁止使用场合请勿使用本产品，以免导致意外事故；
7. 请不要自行拆机改装或维修，以防止出现人身伤害，如有问题或服务需求请联系当地售后服务网点跟进处理。

■ 关于图标含义解释



此符号表示，根据WEEE指令(2012/19/EU)和国家法律，由于这种类型的废弃物
会有潜在的有害物质，可能对环境 and 人类健康产生负面影响，所以本产品不应与您的家庭垃圾一起处置，应将本产品交由授权的电气和电子设备（WEEE）回收站回收。同时，您在正确处理本产品的同时将有助于自然资源的有效利用。如需了解更多有关您可以在何处放置废物回收设备的信息，请联系您当地的城市办事处、废物管理局或家庭废物处理服务部门。

■ 环保说明

产品中有毒有害物质或元素的名称及含量标识表

部件名称	有毒有害物质或元素					
	铅 (Pb)	汞 (Hg)	镉 (Cd)	六价铬 (Cr(VI))	多溴联苯 (PBB)	多溴二苯醚 (PBDE)
塑料部件	○	○	○	○	○	○
金属部件	×	○	○	○	○	○
电路板组件	×	○	○	○	○	○
线缆	×	○	○	○	○	○

本表格依据SJ/T 11364的规定编制。
○: 表示该有害物质在该部件所有均质材料中的含量均在 GB/T 26572规定的限量要求以下。
×: 表示该有害物质至少在该部件的某一均质材料中的含量超出 GB/T 26572规定的限量要求。

此标志为产品的环保使用期限标志，
且此环保使用期限只适用于产品正常工作的温度和湿度等条件。

■ 关于本说明书

本说明书中内容符合截止印刷之日的技术规格。由于得胜公司会不断改进产品，本说明书可能不符合您的特定产品的技术规格。要获取最新版说明书，请访问得胜官网，然后下载说明书文件。技术规格、设备或另售的附件在各个地区可能有所不同，如有问题请与当地得胜销售网点确认。如需更多支持和深层产品信息，请浏览得胜官方网站：

<https://www.takstar.com>

■ Preface

Dear Customer,

Thank you for purchasing Takstar E188 Wired Amplifier - New Edition. To better understand and use the product, please read this manual carefully. If you have any questions or suggestions, please contact our local after-sales service.

■ Features

- Sleek and stylish new design, lightweight and portable.
- Digital amplification with 10W high-power output of high clarity and fidelity.
- Play music wirelessly from devices such as smartphone, computer and tablet.
- Supports multimedia audio playback from USB drives and TF cards.
- AUX audio signal input function lets you use it as a small speaker.
- Built-in 2000mAh rechargeable lithium-ion battery with a battery life of about 15 hours.
- MCU-based smart charging system prevents overcharge and ensures reliability and safety.
- Rugged and durable casing, made of ABS engineering material.
- Multiple wearing options, such as shoulder-worn and waist-worn, for added convenience.

■ Application

- Teaching, tour guide, training, sales, etc.

■ Package Contents

- E188 Voice Amplifier1 PCS
- Wired Headset Microphone1 PCS
- Strap1 PCS
- Charging Cable.....1 PCS
- User Manual1 PCS

■ Specifications

Voice Amplifier

- Frequency Response: 80Hz-18KHz
- Rated Power: 5W
- Peak Power: 10W
- Speaker Impedance: 4 Ω
- Wireless Connection: above V5.0
- Battery Type: li-ion
- Battery Spec: 3.7V/2000mAh
- Working Voltage: DC 3.5-4.2V
- Charging Voltage: DC 5V/1.5A
- Playtime: about 15 hours
- Charging Time: about 1.5 hour
- Charging Port: Type-C
- Dimensions: 100*90*35.5mm
- Weight: about 200g

Headset Microphone

- Capsule: back electret
- Polar Pattern: unidirectional
- Frequency Response: 100Hz-12.5KHz
- Sensitivity: -42~-48dB (0dB=1V/Pa, at 1KHz)

Note: The above data are measured by Takstar laboratory which has the final interpretation right!

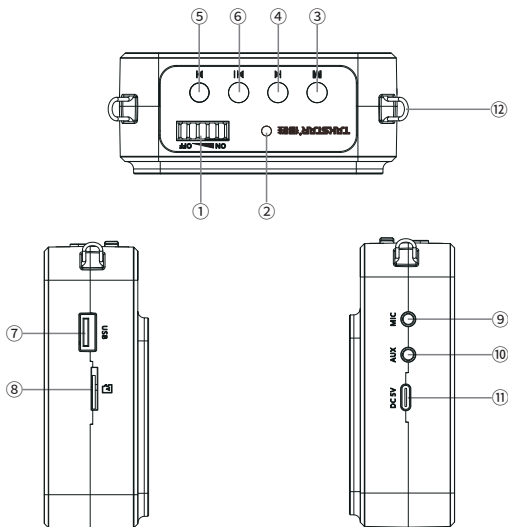
■ Function Descriptions**Voice Amplifier**

① Power switch & volume dial: Rotate the dial to ON until you hear a click to power on the device and then gradually increase the volume level. Once powered on, LED ② will light up blue, meaning the device is ready for voice amplification. Likewise, rotate to OFF to gradually decrease the volume level and eventually power off the device.

② Power indicator: Blue light when sufficient power; red flashes when low power and requires charging; red light while charging and blue light when fully charged.

- ③ **M mode button:** When powered on, short press to switch work mode, accompanied by corresponding voice prompt.
 - ④ **⏮ Previous track button:** In Bluetooth, USB, or TF card mode, short press to switch to the previous track.
 - ⑤ **⏭ Next track button:** In Bluetooth, USB, or TF card mode, short press to switch to the next track.
 - ⑥ **⏸ Play/Pause button:** Short press to play or pause the music. When playing in Bluetooth, long press this button to disconnect Bluetooth.
 - ⑦ **USB interface:** Insert a USB flash drive to play audio files stored in it.
 - ⑧ **TF card slot:** Insert a TF memory card following the correct direction until you hear a click to install it in place. To remove the TF card, press it down until it clicks to eject the card.
- Tip: Please make sure the audio files in the TF card are stored in MP3 and/or WAV format, otherwise it won't be readable and may even damage the device. Please format the TF card to FAT16 or FAT32 file system before copying songs, because other file system (e.g., exFAT, NTFS) will cause failure to save recordings or play songs.**
- ⑨ **MIC input:** Insert a wired mic to start wired voice amplification. Do not point the mic capsule towards the loudspeaker to avoid feedback.
 - ⑩ **AUX input:** Connect to a playback device (e.g., phone, tablet, MP3 player) via a Ø3.5mm audio cable, so to use the amplifier as an active speaker.
 - ⑪ **Charging port:** Charge the amplifier via a Type-C charging cable.
 - ⑫ **Strap clip:** Used to install the shoulder strap for wearing the amplifier across shoulder.

■ **Operation Instructions**

I. How to Use

1. Wear the headset mic on your head correctly, and adjust the pickup angle of the mic.
2. Insert the $\varnothing 3.5\text{mm}$ plug of the wired headset mic into the MIC input interface.
3. Power up the voice amplifier (LED lights up blue) and adjust the volume to an appropriate level.
4. If the power indicator flashes red during use, it means that the battery is running low and requires charging in time.

Tips: It's recommended to fully charge the device upon first use, and if not used for long periods, charge it for once every six months to avoid battery over-discharge which could affect battery performance.

II. Bluetooth pairing

Upon first use, you need to connect this device to your phone or Bluetooth device, following below steps:

1. Power up the amplifier, press [M] to switch to Bluetooth mode and start Bluetooth discovery and pairing, indicated by a flashing blue LED.
2. Enter SETTINGS menu on your phone, find and enable Bluetooth, wait until "TAKSTAR E188" is discovered and tap on it to connect. When connected successfully, there will be a voice prompt about "Bluetooth Connected" , and the LED will become solid blue. Devices such as cell phones, laptops, and tablets can play music via Bluetooth thereafter.
3. The next time you switch to Bluetooth mode, the amplifier will automatically connect to the previously paired device, signaled by a voice prompt "Bluetooth connected" .

■ Safety Instructions

To avoid electric shock, overheat, fire, radiation, explosion, mechanical risk and injury or property loss due to improper use, please read and observe the following items before use:

1. Please check if the power of the connected equipment matches with that of this product before operation. Adjust the volume to proper level during operation. Do not operate at over-power or high-volume level for extended time to avoid product malfunction.
2. If there is any abnormality during use (e.g., smoke, strange odor), please kill the power switch and unplug from power source, then send the product to the local after-sales service for repair.
3. Power adapter used, if any, should be approved by CCC certification or similar standards and comply with the power supply requirements.
4. Keep this product and its accessories in a dry and ventilated area. Do not store in a humid or dusty area for extended time. Keep away from fire, rain, liquid intrusion, bumping, throwing, vibrating, or from blocking any ventilation openings, to prevent malfunction.
5. The product must, when installed on walls or ceilings, be fixed firmly in place at adequate strength to prevent from falling.
6. Please abide by safety rules during operation. Do not use the product in places prohibited by laws or regulations to avoid accident.
7. Do not disassemble or repair the product by yourself to avoid injury. If you have any questions or require any services, please contact our local after-sales service.

■ Label Meanings



This symbol indicates that this product should not be disposed of with your household waste, according to the WEEE directive (2012/19/EU) and your national law. This product should be handed over to an authorized collection site for recycling waste electrical and electronic equipment (WEEE). Improper handling of this type of waste could have a possible negative impact on the environment and human health due to potentially hazardous substances that are generally associated with WEEE. At the same time, your cooperation in the correct disposal of this product will contribute to the effective usage of natural resources. For more information about where you can drop off your waste equipment for recycling, please contact your local city office, waste authority, or your household waste disposal service.

■ About This Manual

This manual contains up-to-date technical specifications as of printing. However, specifications contained herein may not conform to your particular product since Takstar is constantly improving its products. Also, specifications, devices or accessories available may vary from region to region. If you have any questions, please contact our local sales outlet. For the latest version/more information, please visit our website: <https://www.takstar.com/>

注意事项:

1. 本单为保修凭证, 请用户妥善保管, 如有遗失, 恕不保修或退换。
2. 保修期限制: 购买之日起十二个月内。
3. 除了不可抗力事件损坏外, 由本公司负责, 免费维修。
4. 如属保管不善或使用不当造成的损坏, 维修点将酌情收费。
5. 擅自拆卸维修者, 不予保修。
6. 以上保修条款仅限于中国市场适用 (不含港澳台地区)。

产品服务保证书

姓名: _____ 电话: _____ 地址: _____

商品: _____ 型号: _____ 购买日期: _____ 年 ____ 月 ____ 日

维修记录栏 (由维修员填写)	维修员签名	日期

◆ 广东得胜电子有限公司 ◆ 电话: 400-6828-333 ◆ 地址: 广东省惠州市博罗县龙溪街道富康一路2号



扫一扫，了解更多产品
Scan for more
product information

**广东省电声工程技术研究开发中心
广东得胜电子有限公司制造**

地址：广东省惠州市博罗县龙溪街道富康一路2号

服务热线：400 6828 333 传真：0752 6383950

邮箱：xs@takstar.com

网址：www.takstar.com

Guangdong Takstar Electronic Co., Ltd.

Address: No. 2 Fu Kang Yi Rd., Longxi Boluo

Huizhou, Guangdong 516121 China

Tel: 86 752 6383644 Fax: 86 752 6383952

Email: sales@takstar.com

Website: www.takstar.com